

8. Project Narrative

Cover Page

Company Name and Address: Particle Beam Lasers, Inc.
18925 Dearborn Street
Northridge, CA 91324-2807

Principal Investigator: Dr. Stephen A. Kahn

Project Title: HTS Solenoid for Neutron Scattering

Topic No: 17 Instrumentation and Tools for Materials Research
using Neutron Scattering

Subtopic: (a) Advanced Sample Environments

Grant Award No.: DE-SC0019722

Pages 5-7 and 10-14 of this document may contain trade secrets or commercial or financial information that is privileged or confidential and is exempt from public disclosure. Such information shall be used or disclosed only for evaluation purposes or in accordance with a financial assistance or loan agreement between the submitter and the Government. The Government may use or disclose any information that is not appropriately marked or otherwise restricted, regardless of source.

Proprietary Data Legend:

Lines, paragraphs, tables, charts, and other graphics containing trade secrets, commercial, and/or financial information are marked with a highlighted aqua box.

Contents

<u>Identification and Significance of the Problem or Opportunity, and Technical Approach</u>	3
<u>Design requirements for a high field magnet for neutron scattering</u>	3
<u>Magnet design and requirements</u>	4
<u>Technical Approach</u>	5
<u>Degree to which Technical Feasibility has been Demonstrated</u>	5
<u>Magnetic and mechanical analysis of the 25 T design</u>	5
<u>Quench protection</u>	7
<u>Winding and 77 K testing of the conical-shaped HTS coil</u>	8
<u>Anticipated Public Benefits</u>	9
<u>Technical Objectives of Phase II</u>	10
<u>Objective 1: Continue to develop the novel design</u>	10
<u>Objective 2: Demonstration of the new concept in a Proof-of-Principle 17 T HTS solenoid</u>	10
<u>Objective 3: Develop preliminary designs and perform cost estimates of a 25 T solenoid</u>	13
<u>Work Plan</u>	14
<u>Phase II Performance Schedule</u>	15
<u>Facilities and Equipment</u>	16
<u>American-Made</u>	16
<u>Related Research or R&D</u>	16
<u>Team Qualifications; Where and How Tasks Will Be Done</u>	17
<u>How the Research Effort Could Lead to a Product</u>	18
<u>Managerial controls for a successful project</u>	18
<u>Consultants and Subcontractors</u>	18
<u>References</u>	19
<u>Letter of Support from Dr. John M. Tranquada, Neutron Scattering Group Leader at BNL</u>	20

Identification and Significance of the Problem or Opportunity, and Technical Approach

Neutron scattering experiments would benefit from magnets with fields at least 50% more intense than the maximum 17 T presently available from conventional low-temperature superconductors (LTS). A high temperature superconductor (HTS) such as ReBCO, operating at ~4 K as a **high field** superconductor, is essential, because LTS falls far short of the needed combination of critical field and critical current density.

Particle Beam Lasers, Inc. (PBL) and the Superconducting Magnet Division (SMD) of Brookhaven National Laboratory (BNL) propose to advance magnet technology for neutron-scattering experiments by capitalizing upon their expertise and equipment, some of which was developed during several SBIR/STTR collaborations, including ones that designed, built and tested the two HTS solenoids (shown in Fig. 1) that are capable of nesting to generate a field to reach the desired range.



Fig. 1a-d.: High field HTS solenoids built and tested by PBL/BNL collaborations. Left: 25-mm bore pancake coils for insert magnet. Left-center: 7-double-pancake solenoid that generated 16 T. Right-center: Solenoid with 12 double pancakes of 100 mm bore. Right: Nested set. These coils are still available and use of them makes the demonstration of the novel 17 T solenoid design for neutron scattering possible in Phase II.

The inner of these two solenoids, of 25-mm i.d. and 91-mm o.d., operated well at a current density greater than 500 A/mm² and generated nearly 16 T, a world record in 2013 for a magnet exclusively of HTS. The outer solenoid had inner and outer diameters of 100 mm and 163 mm, respectively. A half-length version of the outer solenoid generated more than 6 T at the center (with a maximum field in the conductor of 9.2 T). The design field of the full-length outer solenoid was 10 T, and the combined field of the inner and outer solenoid was 22 T. Since the R&D on the project for which these solenoids were being built was terminated for other reasons, these coils are available for use in the proposed program. While the existing coils are expected to produce a field strength desirable for neutron-scattering, they do not have the desired geometry with a large open view-port region.

These solenoids employed metallic (stainless steel) insulation; the technology led to further R&D at BNL on HTS magnets. BNL has also tested magnets with conventional insulation and no insulation, and the PBL/BNL team will consider these options, too, for neutron-scattering.

The PBL/BNL team plans to use several existing coils from previous SBIRs, as shown in Fig. 1 (in addition to winding some new coils), and we will also use quench detection hardware and technology developed in previous SBIRs to demonstrate a Proof-of-Principle 17 T solenoid. The solenoid will incorporate a geometry with a large open view-port region based on the proposed novel design developed in Phase I. In Phase II we will also generate several preliminary engineering design options of a 25 T magnet that would satisfy the up-to-date requirements of neutron-scattering experiments, getting those requirements from Dr. John Tranquada, Dr. Igor Zaliznyak and other scientists in the field.

Design requirements for a high field magnet for neutron scattering

High magnetic field is an important tool for tuning the state of matter, creating new states and quantum phases, and changing the fundamental properties of materials. Magnetic fields can modify transport properties of conductors, correlations in magnetic insulators, and the way conduction electrons interact with atomic moments in magnetic metals. Neutron-scattering techniques provide a powerful tool for studying these atomic, molecular and microscopic properties and correlations in condensed matter systems. The importance of developing high magnetic field environments for such studies has therefore been widely appreciated, e.g., in the National Research Council of the National Academy of Sciences report “High Magnetic Field Science and Its Application in the United States: Status and Future Directions”.^[1] Workshops by the ORNL Neutron Science Directorate^[2-4] discussed advances in high magnetic field science and practical routes for building high-field magnets for neutron scattering to enable the new science that neutron-scattering measurements in high magnetic fields can provide. The most recent Workshop^[4] focused on the new opportunities provided by the progress in the commercial development of high-temperature superconductor technology.

LTS magnets for neutron-scattering measurements can reach only 15 T to 17 T. To reach 25 T, the dedicated beam line EXED at the Helmholtz Zentrum, Berlin (HZB)^[5,6] required a field boost of 11 T from resistive coils consuming 4.4 MW. The magnetic field is horizontal, with a viewing angle of only 30°. The geometry severely limits neutron spectroscopic studies, which require rotation of the sample with respect to the detector array and the incident beam in order to explore its reciprocal space. HTS coils may be able to deliver magnetic fields as intense as 25 T.^[4] A 25 T split-coil, vertical-field magnet could be similar in usability and versatility to the LTS systems that are currently the mainstay of neutron scattering studies in magnetic fields below ~15 T. Ideally, the magnet would be experiment-friendly, with large viewing ports (~90°-180° horizontally and 5°-15° vertically) and compact and portable between different neutron spectrometers, rather than requiring a dedicated beam line.

Magnet design and requirements

The main requirement for a neutron-scattering magnet is a large solid angle for the passage of incident and scattered beams, unobscured by the magnet coils and their bulky support structures. Especially for time-of-flight (TOF) neutron spectroscopy, the viewing ports should be as free as possible of material, to avoid spurious TOF background features from neutrons scattering in, for example, thin aluminum cylinders separating the members of a split-coil pair.^[7-9]

Table 1: Main technical specs of a 20-25 T magnet for diffraction measurements

Maximum field	25T
Field homogeneity:	< ½% over 10 mm DSV; < 1.4% over 15 mm dia & 15 mm high
Stray field (at max field)	≤ 0.1T @ 2m; ≤ 0.01T @ 4m
Open bore diameter	40 mm
Coil split height	20 mm
Vertical opening	-5° to +5°, flaring from ±7.5 mm, the ends of the sample
Horizontal opening, option #1	Two openings, first 120° and second 60° (180° total)
Horizontal opening, option #2	4 openings, each 60° with 20 mm for beam
Magnet bath temperature	4.2 K

The vertical-field, split-coil geometry is compatible with the sample rotation techniques for broad surveys of reciprocal space. Furthermore, stray fields at the side of magnets are lower than near the axis and easier to shield or to mitigate using compensation coils. Additionally, the geometry more easily accommodates

May contain trade secrets or commercial or financial information that is privileged or confidential and exempt from public disclosure. Such proprietary information is highlighted.

³He and dilution-refrigeration inserts, pressure cells, and high-temperature inserts, providing opportunities for neutron studies under multiple extreme thermodynamic conditions. For these reasons, the recommendation of the Ultra-High Field Magnets for X-Ray and Neutron Scattering Using High Temperature Superconductors Workshop was to concentrate on developing magnets with the vertical-field, split-coil geometry.^[4]

Technical Approach

The new design approach that is being developed as a part of this SBIR/STTR (see Fig. 2), employs magnetic attraction instead of mechanical support for the “inboard” coils of a magnet with multiple nested split-solenoids—i.e., solenoids with a midplane gap, as in a Helmholtz pair. Coils “Ou” and “Od” that are “outboard” (i.e., relatively far from the magnet midplane) magnetically attract inboard coils “Iu” and “Id” so strongly as to overpower the attractive force from coils on the opposite side of the magnet midplane. These inboard coils therefore, in principle, need no midplane-straddling structure for mechanical support. An essential elimination of the need of support structure between the inboard coils above and below the midplane allows a reduction in the spacing between the inboard coils and therefore improves the magnetic efficiency. Support for the outboard coils straddles the midplane, but at a radius so large as to block little of the circumference of the midplane viewing port. The structure may be considered like that of a pillar structure for a bridge over a river where a few pillars take the forces while allowing openings for the boats and water to flow. The design is an axisymmetric version of the open-midplane dipole design^[11,12] proposed fifteen years ago by Ramesh Gupta and pioneered by a collaboration of PBL and BNL^[13].

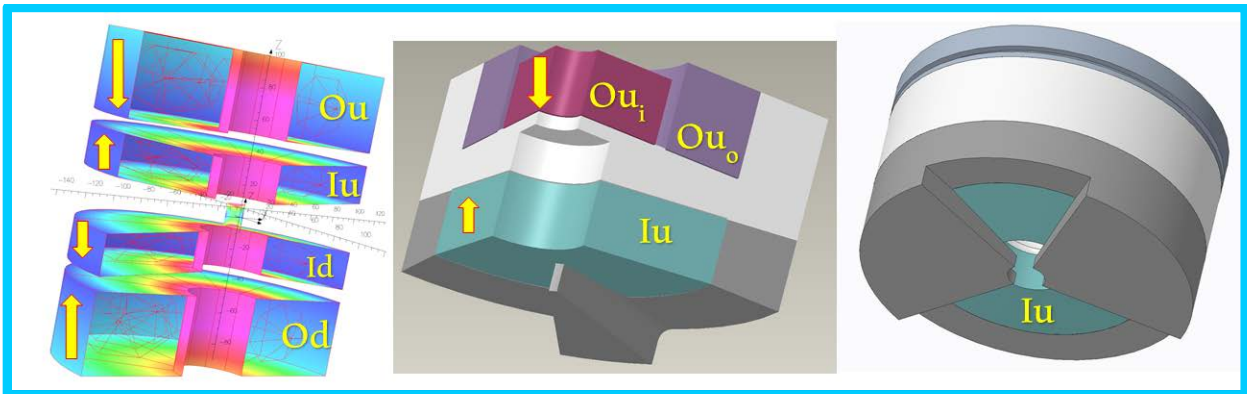

Fig. 2. Left: Cutaway view of the magnet coils with field contours and vertical direction of the Lorentz force superimposed. Center: Mechanical model of the upper quarter of the structure for option #2 (4 openings, each 60° with 20 mm for beam). Right: Model of the upper coils for option #1 (2 openings, 120° and 60°, 180° total).

To maximize viewing port angles and magnet efficiency, the designs portray inboard coils “Iu” and “Id” as conical with a cross section that is not rectangular but is either a parallelogram or shaved on one corner to avoid intruding on the viewing port. Fig. 2 shows a magnetic design of the concept with conical inboard coils and mechanical structure concepts with symmetric and asymmetric openings. Arrows show the direction of vertical Lorentz forces. The inboard and outboard coils may be radially split (an example is shown in the center model of Fig 2 with outboard coils split in “Ou_i” and “Ou_o”).

Degree to which Technical Feasibility has been Demonstrated

The primary tasks of Phase I were (a) to perform detailed analyses of fields, stresses, strains, deformations and energy storage and to determine the quench protection system, and (b) wind and test a conical-shaped HTS pancake coil. This section highlights the demonstration of the technical feasibility,

May contain trade secrets or commercial or financial information that is privileged or confidential and exempt from public disclosure. Such proprietary information is highlighted.

including preliminary CAD models. These are significant accomplishments for a Phase I program, which allows us to make a strong Phase II proposal.

Magnetic and mechanical analysis of the 25 T design

Figures 3 and 4 reveal the geometry of three illustrative designs that were examined in Phase I to generate a 25 T field for neutron scattering experiments using Low Temperature Superconductor (LTS) and ReBCO tape. Figure 3 presents views from above of a quadrant of the upper half of each magnet. Figure 4 presents views from below, to show the wedge supports.

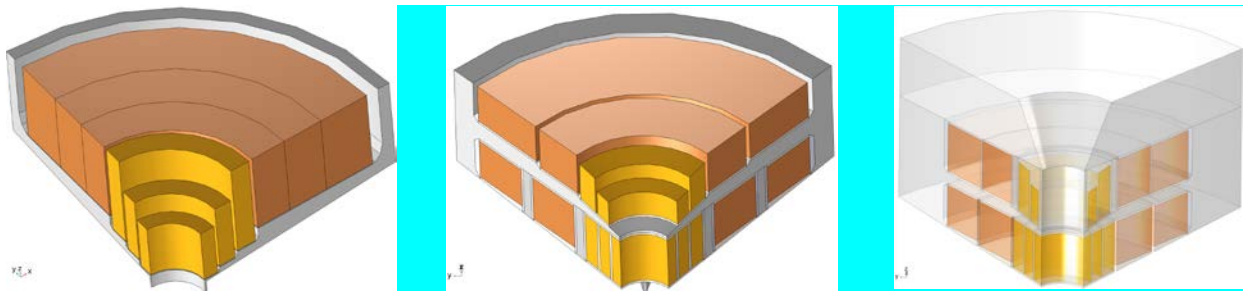

Fig. 3a-c. Views from above a quadrant of the upper half of illustrative magnets to meet the specs of Table I. Gold-colored is ReBCO tape; copper-colored is low-temperature superconductor (LTS); grey is support-structure material, likely stainless steel. Left: Coils supported by platen near magnet midplane. Center: Outboard coils supported by platen bearing on rings resting on midplane pie wedges. Right: Platen supported by rings extending downward from thick outboard cantilever.

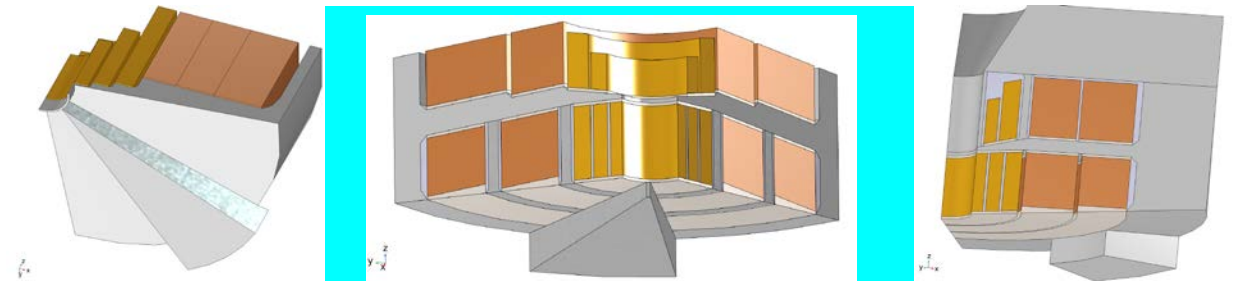

Fig. 4a-c. Views from below a quadrant of the upper half of the illustrative magnets of Fig. 3. Below each quadrant is a pie wedge (blunt-nosed in 4c), flaring axially by 5° and circumferentially by ~30°, that bears the cross-midplane force of attraction between the coils above and below the magnet midplane.

Figures 3 and 4 show three approaches to support the coils against the large Lorentz forces. Figures 3a and 4a show a geometry in which coils bear on a platen near the magnet midplane, which in turn bears on pie wedges to carry across the magnet midplane the enormous force with which one half magnet attracts its mate across the magnet midplane. Figures 3b and 4b show a design in which the platen is much further from the magnet midplane, thereby displacing conductor that is much less efficient at generating magnetic field. Figures 3c and 4c show a design that threads the load-bearing rings through radial gaps between outboard coils rather than inboard ones, displacing conductor to a region of even lower field-generating efficiency. Because the cross-midplane support is now at such a large radius, it need block only a small fraction of the available circumference.

Magnetic and mechanical design, calculations and optimization were carried out for all three cases with the codes COMSOL, OPERA and ANSYS and reported in detail in the Phase I final report attached to this proposal. We were able to develop satisfactory designs for all three cases. In this section we

May contain trade secrets or commercial or financial information that is privileged or confidential and exempt from public disclosure. Such proprietary information is highlighted.

summarize the calculation for the geometry of Figs. 3c/4c, in which support of the outboard coils is from a robust cantilever supported by a comparably robust radial ring outside the coils. The peak field on the coils for this 25 T vertically-split solenoid is 28.2 T on the inboard coil as shown in Fig. 5 (left). Fig. 5 (center) shows the field uniformity and Fig. 5 (right) shows the Lorentz force density.

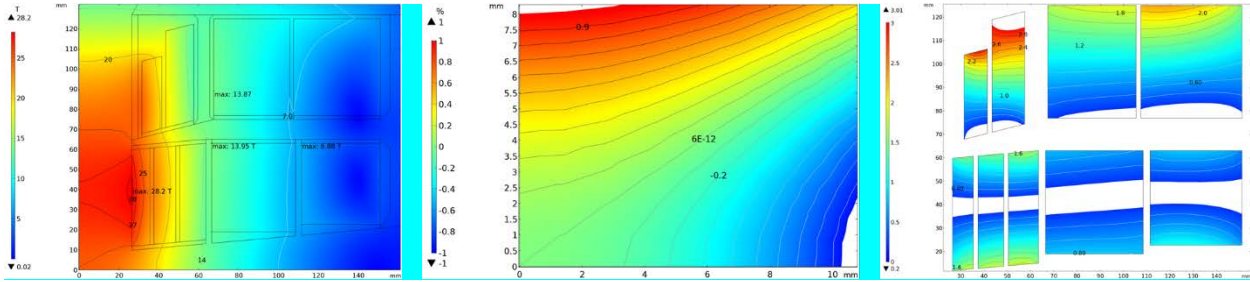

Fig. 5. Left: Magnitude of the field B for the magnet of Figs. 3c/4c. B_{\max} in the ReBCO tape is 28.2 T, the magnetic energy is 1.104 MJ. Center: The field homogeneity is 1.32% over a cylinder of 7.5 mm radius and half-length. Right: Absolute value of density of axial Lorentz force. Magnetic attraction from outboard coils attracts inboard coils upward, overpowering the downward attraction from coils on the opposite side of the midplane.

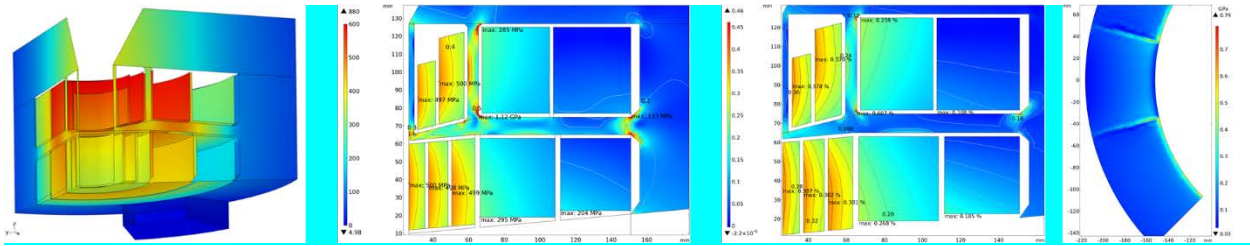

Fig. 6. Left-most: Axial displacements δ_z , magnified twenty-fold. Left-middle: Von Mises stress, σ_{VM} . Right-middle: First principal strain ϵ_1 . Right-most: Localized von Mises stress concentrations where the support rings bear on the top of the pie wedge.

Figure 6 (left-most) plots the axial displacement with a support structure with a Young's modulus of 208 GPa. With a support structure this massive, its maximum axial displacement is a mere 0.44 mm. the displacement in the conductors is slightly more: 0.53 mm. Figure 6 (left-middle) plots the von Mises stress (σ_{eqv}). In all five ReBCO coils σ_{eqv} is just shy of 500 MPa, providing a 20% margin to the 600 MPa maximum recommended for the conductor. The more than 1 GPa stress concentration at corners between the platen and rings is so localized as to be of little concern; further analysis done early in Phase II will verify this or modify the design if need be. Figure 6 (right-middle) plots the first principal strain, ϵ_1 . In each ReBCO coil, ϵ_1 is approximately 0.38%, providing a nearly 20% margin to the 0.45% maximum recommended for the ReBCO tape that we plan to use. Figure 6 (right-most) plots the von Mises stress concentrations where the pie wedge supports the outermost ring. The maximum von Mises stress reaches only 0.79 GPa in the ring and 0.644 GPa in the pie wedge.

Quench protection

Quench protection of HTS magnets is an important part of the development of very high field magnet technology. BNL and PBL/BNL teams have been at the forefront of this technology. In particular, the PBL/BNL team has developed a multi-pronged approach under a previous SBIR^[14] that will be used to protect the HTS coils in Phase II. This includes an advanced quench detection and protection system (Fig. 7), which detects a pre-quench voltage at the level of a few hundred milli-volts and allows fast energy

extraction by tolerating well over a kV. The system uses metallic-insulation windings and inductively coupled copper discs to rapidly drop current (see Fig. 7 for a rapid drop from 285 A to 230 A). BNL has used such a system in successfully protecting many HTS R&D magnets including: those for the Facility of Rare Isotope Beams^[15]; a PBL/BNL high field HTS solenoids for Muon colliders^[16, 17]; a high field HTS solenoid for Superconducting Magnetic Energy Storage (SMES)^[18]; a PBL/BNL HTS/LTS hybrid dipole^[19]; and a high field HTS solenoid for Axion search^[20]. Detailed calculations and specific optimization of the quench protection system for the proof-of-principle neutron-scattering solenoid will be carried out during the Phase II project.

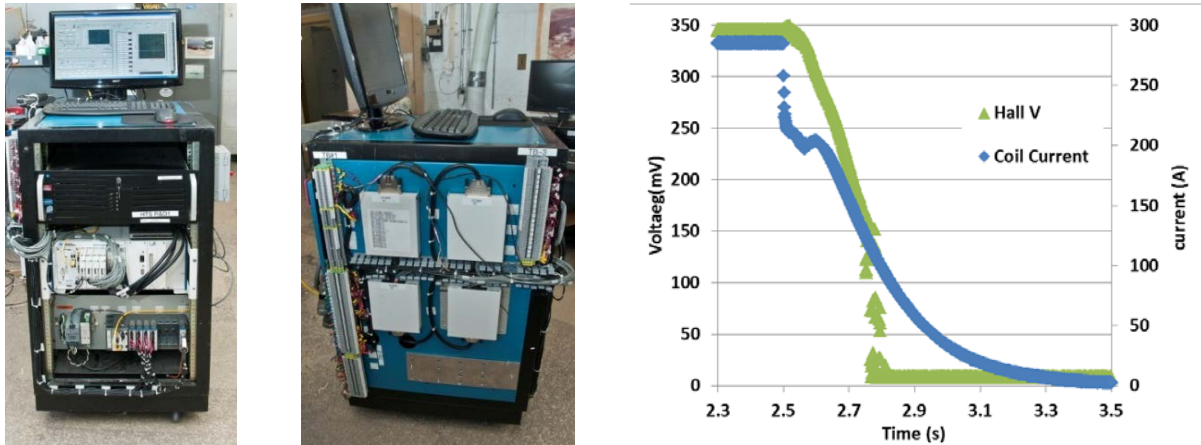

Fig. 7a-c. Quench-detection and magnet-protection system developed during PBL/BNL collaborations. Left & center: Hardware (32 channels, 1 kV). Right: Time dependence of magnet's central field, as measured by Hall voltage, and current during rapid shutdown. This technology will be used in protecting HTS coils in Phase II.

Winding and 77 K testing of the conical-shaped HTS coil

As a part of the Phase I effort, a coil having a cone angle of 15 degrees was wound with 88 meters of 12 mm wide HTS tape with several voltage taps installed for diagnostics (see Fig. 8). The coil i.d. was 50.8 mm, o.d. 127 mm and it had 315 turns. The no-insulation technique was used to evaluate the defect tolerance in the winding via a series of four 77 K tests.



Fig. 8. Two views of the conical coil wound in Phase I.

The details of coil construction and testing are given in the attached Phase I Final Report. Fig. 9 (left) shows the conical coil getting prepared for testing in liquid nitrogen. Fig. 9 (right) shows the voltage as a function of current at 77 K during the 4th test after uncovering and removing defective conductor. (Defective conductor was found in earlier tests.)

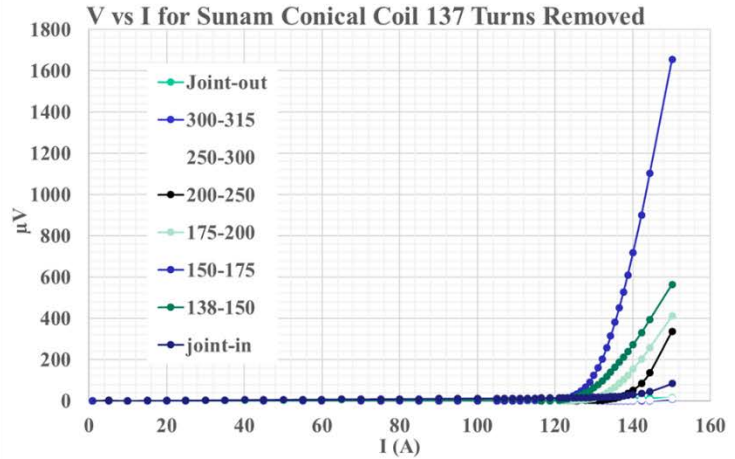
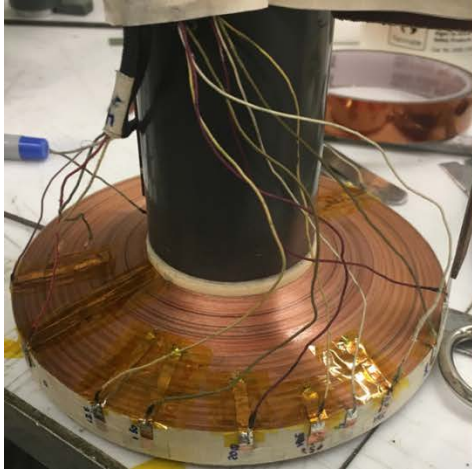

Fig. 9. Left: Conical HTS coil getting prepared for the first test in liquid nitrogen. Voltage as a function of current in test #4 after the defective section was removed.

The conical coil reached the expected performance, implying the success of the conical winding. The coil with no defective conductor was able to reach a higher current in test #4 as compared to the coil in test #1 (as discussed in the Phase I Final Report, the coil in test #1 had a defect). The higher current in test #4 was primarily due to the fact the coil in test #4 had a fewer turns and a larger inner diameter and hence a lower maximum field on the conductor than the coil in test #1.

Anticipated Public Benefits

A publication^[10] by the Institute of Physics states, “Neutron scattering is routinely used in modern science to understand material properties on the atomic scale. Originally developed as a tool for physics, the method has led to advances in many areas of science, from clean energy and the environment, pharmaceuticals and healthcare, through to nanotechnology, materials engineering, fundamental physics and information technology.

“Neutron scattering is used in many different scientific fields. Neutrons can be used to study the dynamics of chemical reactions at interfaces for chemical and biochemical engineering, in food science, drug synthesis and healthcare. Neutrons can probe deep into solid objects such as turbine blades, gas pipelines and welds to give microscopic insight into the strains and stresses that affect the operational lifetimes of crucial engineering components. Neutron studies of nano-particles, low-dimensional systems and magnetism are used for the development of next-generation computer and IT technology, data storage, sensors and superconducting materials. Neutron scattering is a delicate and non-destructive measurement technique, making it ideal for use in heritage science. ...

“Neutron scattering can be used to address the global challenges facing society, and to make developments that have immediate or long-term economic impact.”

Many consider neutron scattering to be the most valuable of all tools for investigating matter of all sorts, employing many thousands of researchers, as evidenced by organizations such as the Neutron Scattering Society of America, Asia-Oceania Neutron Scattering Association, and the European Neutron Scattering Association. Their research is of extreme commercial as well as intellectual value, justifying the expenditure of billions of dollars on neutron sources and detectors, including magnets such as those from HTS-110, a division of the SCOTT Group.

As with nuclear magnetic resonance, increased magnetic field intensity markedly expands the frontiers of science that can be studied and enable new discoveries. The R&D proposed by this SBIR/STTR, to develop the technology to design, fabricate and test proof-of principle and prototype magnets, has the

May contain trade secrets or commercial or financial information that is privileged or confidential and exempt from public disclosure. Such proprietary information is highlighted.

potential to broaden and deepen greatly the value of neutron scattering, carrying it into a new regime of utility. Developing the technology for such magnets is vital for their success, and therefore amply justifies the investment.

Technical Objectives of Phase II

The first major objective of our Phase II proposal is to continue to develop the promising concept of an open-midplane design of a high field neutron scattering solenoid with conical coils. The cost of building a 25 T magnet is, of course, well beyond the budget of a Phase II SBIR/STTR. However, the PBL/BNL team is in a unique position with an inventory of HTS coils from previous SBIR programs. This allows us to propose the second major objective of designing, building and testing a reasonably high field (~17 T) Proof-of-Principle HTS magnet for neutron scattering containing the appealing features of the open midplane design and conical coils. The prototype test magnet proposed here is itself a ~17 T fully HTS compact solenoid that would outperform existing LTS solenoids for lower field applications. Such magnets are currently unavailable, and their development and possible commercialization are highly desirable. The third objective is to develop preliminary engineering design options for a 25 T vertically split solenoid satisfying various requirements. The PBL/BNL team will also perform cost estimates of building such a 25 T magnet for various options.

Objective 1: Continue to develop the novel design

While we perform the specific Proof-of-Principle demonstration of a ~17 T solenoid outlined in objective 2 and develop the preliminary engineering design of 25 T solenoids outlined in objective 3, the purpose of objective 1 is to further develop the overall design with magnetic and mechanical modelling and practical engineering. In addition, the PBL/BNL team will continue to seek the input of the user community to update the design parameters and other requirements. (User institutions will include BNL and ORNL, which helped in updating the Phase I parameters and provided important guidance during Phase I).

Objective 2: Demonstration of the new concept in a Proof-of-Principle 17 T HTS solenoid

For the Phase II project we plan to design, fabricate and test a proof-of-principle magnet (see Fig. 10, left) that will be suitable for a neutron scattering experimental facility. We will use a split-coil approach with an open mid-plane gap. Figure 10 shows the magnet geometry. The coils closest to the mid-plane will be conical coils similar to those in Fig. 8 but with a 5° cone angle. The plan for the inner and outer coils is to use coils that were wound previously by PBL/BNL for an earlier SBIR project^[14]. The use of the coils from the previous project makes possible the ambitious task of designing, building and testing a 17 T magnet using HTS conductor within the Phase II budgetary constraints. New conical coils needed to complete construction of the 17 T magnet will be wound during the project. The magnet built in Phase II will meet the field uniformity requirements listed in Table 1. The magnet will be instrumented with voltage-taps, Hall probes, temperature sensors, strain gauges, etc. for diagnostics. Copper discs will be added, which are inductively coupled with the magnet coils for quench protection. As mentioned earlier, such discs have helped in a rapid partial energy extraction at the onset of a quench. The magnet system will be tested in the BNL cryogenic test facility.

The purpose of the proposed coil arrangement is to have the outboard coils provide an attractive force on the inboard coils to counteract the force from the coils on the other side of the mid-plane gap. The mid-plane gap will be 20 mm. The position of the outboard coils will be selected so as to minimize the force on the inboard coils. Figure 10 (right) shows the total force on the inboard (conical) coil coming from both the adjacent outboard coil and the coils across the mid-plane. The figure shows that at a distance of ~50 mm the force can be eliminated. The peak field in the coils and the field at the magnet center are also

May contain trade secrets or commercial or financial information that is privileged or confidential and exempt from public disclosure. Such proprietary information is highlighted.

a function of the distance between the inboard conical coils and the outboard coils. At a distance of 50 mm the peak field in the coils is 21 T when the field at the center is 17 T.

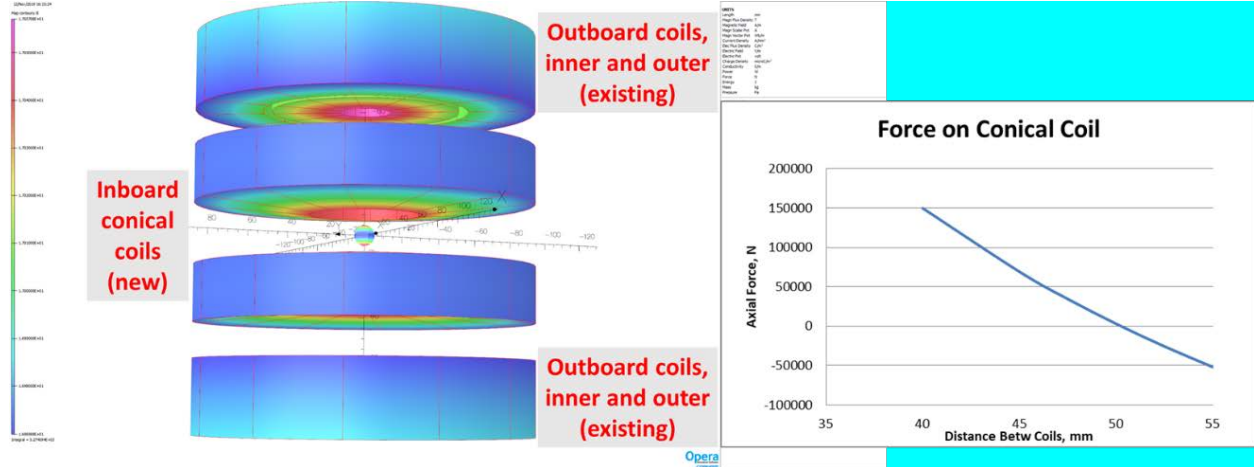

Figure 10: Arrangement of coils for the proposed Proof-of-Principle demonstration magnet for neutron scattering is shown on the left. The inboard (conical) coils are wound with a 5° cone angle to flare the mid-plane opening. A positive force on the conical coil is away from the midplane and is plotted as a function of distance on right.

The mechanical performance of this magnet system is of prime importance. We have performed preliminary 2D and 3D structural simulations using ANSYS which support this proposal.

2D ANSYS analysis

The 2D ANSYS analysis gives information on the distortions, stress and strain on the coils and support structure. Figure 11 (left) shows the geometry of the 2D model. The aluminum wedge shown in green covers only a limited fraction of the azimuthal space to provide maximal space at the mid-plane for the incident and scattered beams. The 2D model assumes cylindrical symmetry, which is not true for the wedge configuration at the mid-plane. The mid-plane wedge will be handled properly in the Phase II 3D analysis. Figure 11 (right) shows the deformations of the magnet system as it is energized to 17 T. Figure 12 shows the von Mises equivalent stress and hoop strain for this model. The maximum values of these variables on the different coils and the support structure are tabulated in Table II. The values shown in the table are within acceptable limits. This analysis is preliminary at this time; we expect to improve it in Phase II.

Table II: Maximum mechanical variables for the cylindrically symmetric 2D model.

Variable	Conical Coil	Insert Coil*	Outsert Coil*	Al Support	SS Support
Peak Field, T	19.0	21.1	11.1		
Max. Displacement, μm	114	114	90	63	1500
Max. Von Mises Stress, MPa	368	339	209	176	434
Max. Strain	0.29%	0.27%	0.17%	0.26%	0.22%

*Note that the outboard coils are made up of an insert coil inside of an “outsert” coil, and that those coils already exist as part of an earlier PBL/BNL SBIR.

May contain trade secrets or commercial or financial information that is privileged or confidential and exempt from public disclosure. Such proprietary information is highlighted.

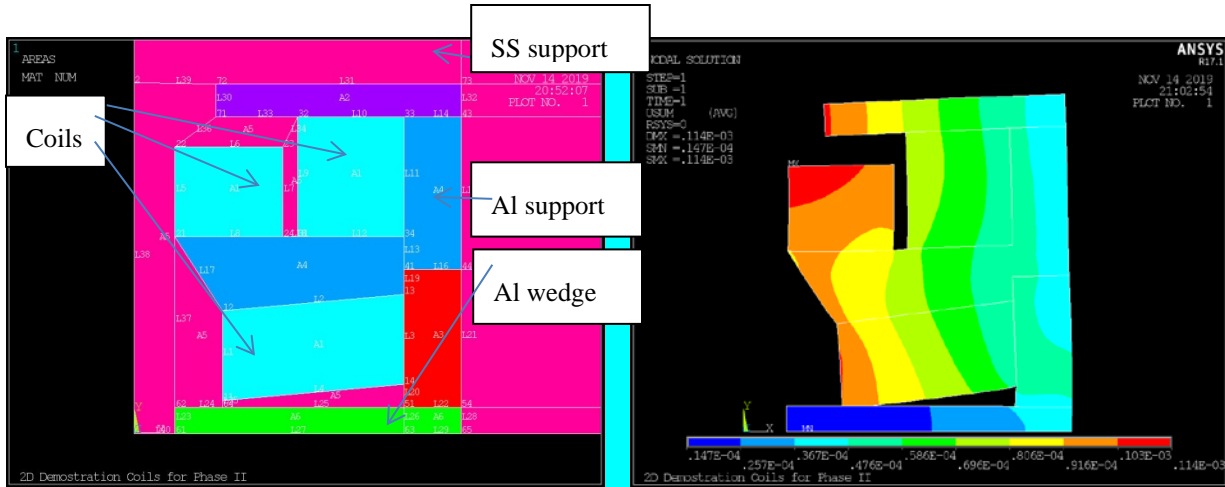

Figure 11: (Left) Geometry of 2D model of Phase II demonstration magnet system. (Right) Deformations seen when the magnet is energized to 17 T.

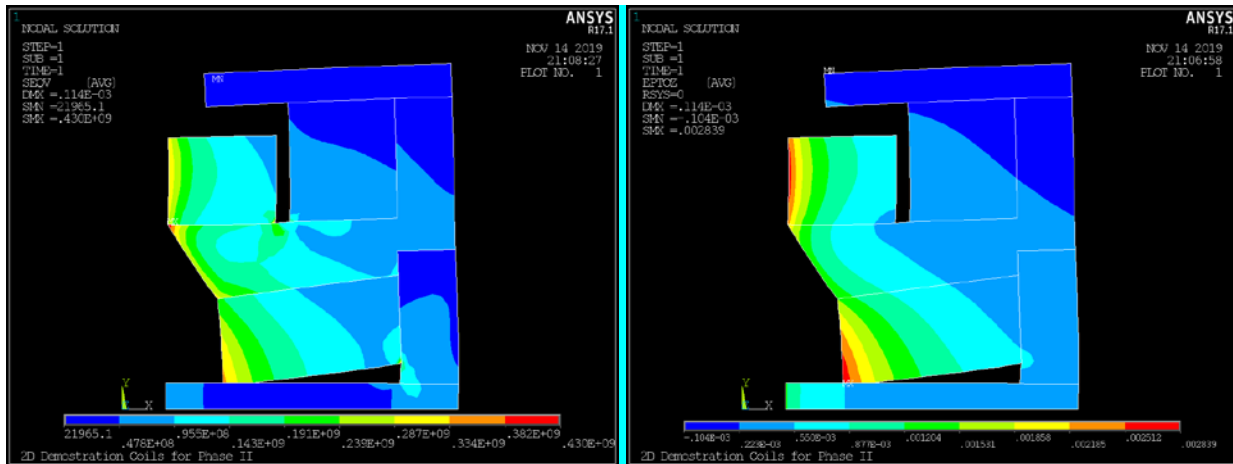

Figure 12: (Left) Von Mises stress and (right) hoop strain are shown for the 2D model.

3D ANSYS analysis

The 3D analysis is important for the design of the mid-plane support structure. It is necessary to have maximum open space at the mid-plane for the incident and scattered beams. Also, the support structure at the mid-plane must be made of aluminum (with minimal thickness) since it is more transparent to neutrons than stainless steel. We have examined several mid-plane support configurations that might be useful to the neutron scattering community. Figure 13 shows two views of a configuration with four 30° wedges (4×30°) positioned with a 20 mm space for the incident beam. Figure 14 (left) shows the deformation contour plot. The plot shows a maximum displacement of 0.25 mm, which occurs at the center of the unsupported portion between the wedges. The von Mises stress is shown on the right part of the figure. The maximum stress occurs at the edge of the wedge where it is supporting the upper structure.

May contain trade secrets or commercial or financial information that is privileged or confidential and exempt from public disclosure. Such proprietary information is highlighted.

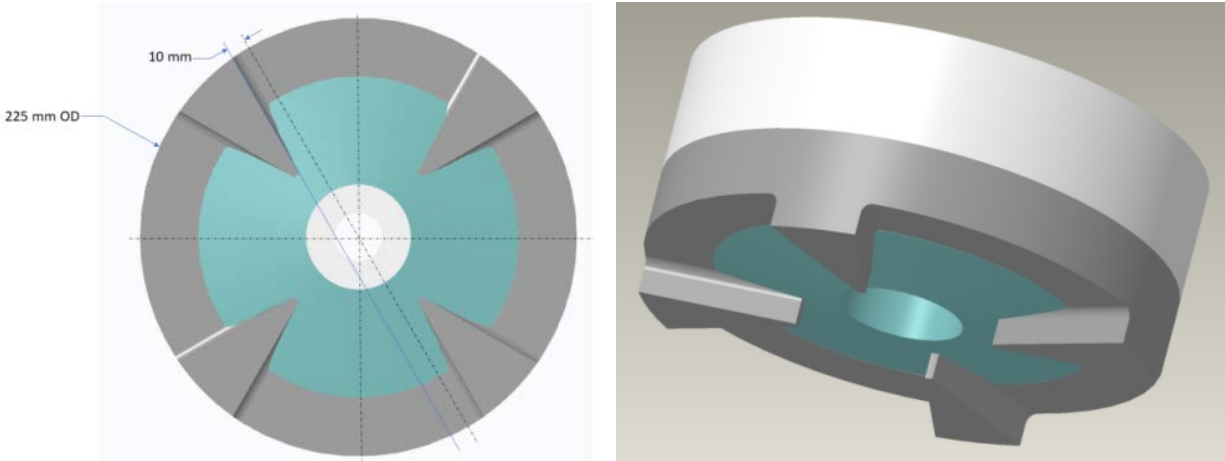

Figure 13: Two views of the $4 \times 30^\circ$ mid-plane wedge configuration.

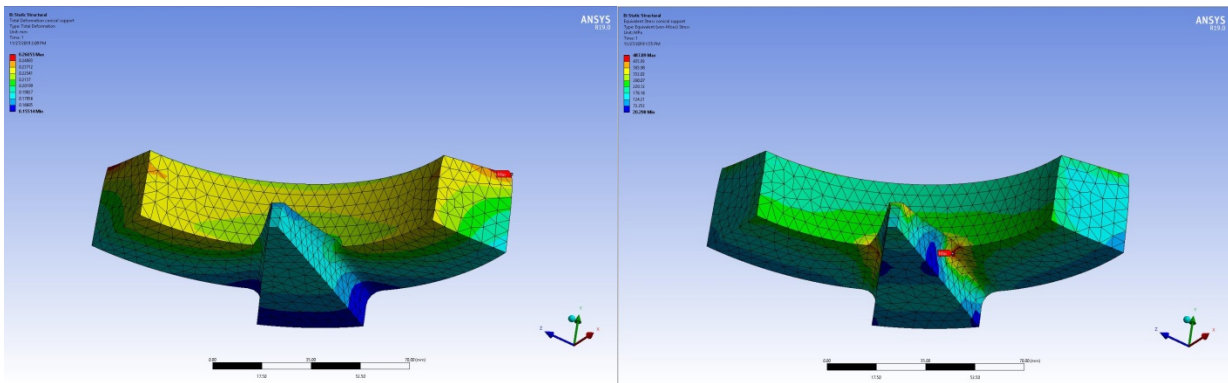

Figure 14: (Left) Deformation contour plot of the $4 \times 30^\circ$ wedge configuration. (Right) Von Mises stress plot.

Objective 3: Develop preliminary designs and perform cost estimates of a 25 T solenoid

We will further optimize and develop preliminary designs of the 25 T solenoid based on the PBL/BNL novel design for (a) the HTS/LTS hybrid design as shown in Figs. 3&4 (discussed in more detail in the attached Phase I Final Report) and (b) an all HTS option that is based on 12 mm HTS tape from SuperPower (<http://www.superpower-inc.com/>) that meets the field uniformity requirements given in Table 1 and a preliminary magnetic design shown below in Fig. 15. We will examine both metallic-insulation windings and no-insulation windings. For the metallic-insulation, it is likely to be a two-layer coil design, whereas for the no-insulation windings, it will definitely be a single layer coil design to avoid asymmetric (or relative) Lorentz forces between the inner and outer layer when the current bypasses across turns in some windings.

PBL, with the experienced engineering team at BNL, will carry out the cost estimates of building such a magnet for a Neutron scattering facility for various design options.

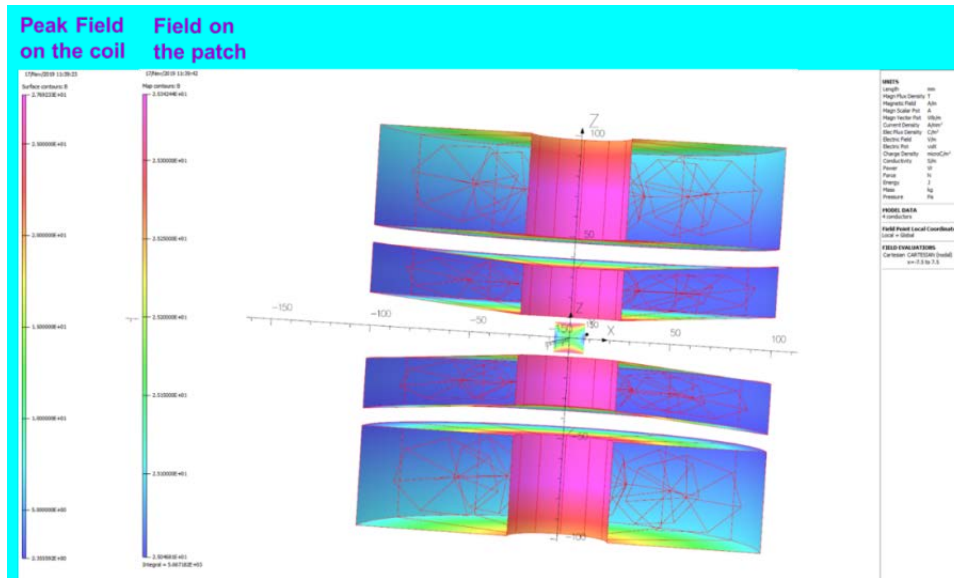

Fig. 15. Cutout view of the peak field (27.7 T) on the surface of the 25 T solenoid and field on a 15 mm diameter and 15 mm high area.

Work Plan

To achieve the technical objectives mentioned in the previous section in a period of 24 months, the Phase II Work Plan will consist of several specific tasks as listed below. We also list the roles of the teams. The project benefits from the fact that PBL PI (Dr. Kahn) is based near, and has a guest appointment and an office at, BNL.

Task 1: Continue to develop our novel design. We will continue to develop the conceptual, magnetic and mechanical design of our novel magnet to make it efficient and easy to build. We will continue to seek input from the user community. This task will be jointly performed by the PBL and BNL teams.

Task 2: Finalize the magnetic design of the Proof-of-Principle magnet. The magnetic design of the Proof-of-Principle 17 T demonstration solenoid will be further optimized and finalized to allow placing the order for the conductor and finalizing the mechanical design. This task will be jointly performed by the PBL and BNL teams.

Task 3: Develop conductor specifications and place purchase order. Conductor specifications will be finalized, and an order will be placed. The conductor is a long lead time item; and the currently expected delivery date is five to eight months from the date the order is placed. This task will be primarily carried out by PBL, with assistance from BNL.

Task 4: Finalize the mechanical and engineering design of the Proof-of-Principle magnet. The mechanical and engineering design of the proof-of-principle magnet will be finalized for the magnet that has its magnetic design completed in Task 2. The mechanical and the magnetic design will be iterated together and feedback from engineering staff on the magnet assembly will be sought throughout the process. This task will be primarily carried out by the PBL with assistance from BNL.

Task 5: Place purchase orders for the magnet structure parts. The purchase orders for the magnet parts will be placed soon after the completion of Tasks 2 and 4. This includes parts for the support structure and copper discs to aid in the initial rapid energy extraction during quenching. This task will be primarily carried out by the PBL with assistance from BNL.

Task 6: Perform 77 K QA test of the existing PBL coils and select those to be used in the Proof-of-Principle magnet. PBL HTS coils from previous SBIRs are stored at BNL. BNL will make the selection from existing coils for use in the Proof-of-Principle demonstration magnet. Only those coils that perform

well at 77 K will be used. Our inventory is more than twice what is required for the demonstration magnet, enabling this choice. This task will be carried out by BNL, with joint participation with PBL.

Task 7: Perform winding of new coils and perform 77 K QA testing. Two sets of new conical coils will be wound with the conductor purchased. These coils will also be tested at 77 K. One set of coils will go above the midplane and the other set below the midplane. This task will be primarily carried out by BNL, with input from PBL.

Task 8: Complete the assembly of the Proof-of-Principle magnet. The newly wound conical coils from Task 7, the selected coils from Task 6, the copper discs and support structure made from parts procured in Task 5 will be assembled into the Proof-of-Principle magnet. This task will be primarily carried out by BNL, with input from PBL.

Task 9: Perform 77 K test of completed magnet. A test of the completed magnet will be performed at 77 K as a final QA check.

Task 10: Perform 4 K test of Proof-of-Principle magnet. A high field 4 K test of the Proof-of-Principle ~17 T magnet will be carried out at the cryogenic test facilities at BNL. BNL’s advanced quench detection and protection system will be used. This task will be primarily carried out by BNL, with the active participation by the PBL team.

Task 11: Perform preliminary engineering designs and cost estimates of a 25 T magnet for various options. Preliminary designs of a 25 T magnet for a neutron scattering solenoid (Objective 3) will be carried out for the HTS/LTS hybrid and the all-HTS magnet based on the novel concept developed during the course of this proposal. The all-HTS magnet will have two further options – metallic-insulation and no-insulation. The details of quench protection are likely to be different for each case. We will also perform the cost estimates for various options. This task will be jointly carried out by the PBL/BNL team.

Task 12: Explore the construction of a user magnet beyond Phase II. Towards the end of this project and based on the results of the Proof-of-Principle demonstration magnet, the PBL/BNL team will explore construction of a 25 T user magnet for neutron scattering. This will include a preliminary cost estimate of such a magnet in a cryostat.

Task 13: Write the Phase II Final Report. Both the PBL and BNL teams will participate in writing the Phase II final report.

Phase II Performance Schedule

The project duration will be 104 weeks (24 months). The following is the schedule of Tasks corresponding to the Objectives listed in the work plan:

	MONTHS																							
	1	2	3	4	5	6	7	8	9	10	11	12	13	14	15	16	17	18	19	20	21	22	23	24
Task 1																								
Task 2																								
Task 3																								
Task 4																								
Task 5																								
Task 6																								
Task 7																								
Task 8																								
Task 9																								
Task 10																								
Task 11																								
Task 12																								
Task 13																								

Facilities and Equipment

The applicant has been successful in prior years obtaining SBIR grants and has experience complying with federal government grant guidelines and regulations and working with federal grant officers. The Phase II work described above will be carried out in office space in Midlothian, TX, the home office of the principal investigator in Upton, NY, and the home offices of the other PBL, Inc. employees, and at BNL. Company-furnished computer hardware and public-domain software will be used as appropriate.

The facilities and personnel of the BNL Magnet group will lead the Phase II effort to construct and test coils. BNL's SMD has been a major contributor to the development of magnets for many decades. The SMD has extensive facilities for winding coils and testing them. It also has simulation and engineering software tools that will aid in the design of coils and magnets—ROXIE, OPERA2d, OPERA3d and in-house software for magnetic design, ANSYS for mechanical design, and Creo, Pro/ENGINEER and AutoCAD for engineering design.

The SMD has a staff of about 30, including scientists, engineers, technicians and administrative staff. Construction and test of coils will be in the SMD's 55,000 ft² multipurpose R&D complex. A prominent asset of the complex is an active cryogenic test facility, complete with high-current, high-resolution and high-stability power supplies.

The facility allows testing of a variety of superconductors, coils and magnets from ~2 K to ~80 K. Dedicated equipment includes several computer-controlled, automated coil-winding machines, automated-cycle curing and soldering stations, centralized exhaust-vent systems, hydraulic presses and two machine shops adequate for most of the components needed for the R&D task. BNL also has a central machine shop and a procurement group to handle orders with private companies.

American-Made

To the extent possible in keeping with the overall purposes of the program, PBL will endeavor to ensure that only American-made equipment and products will be purchased with the funds provided by the financial assistance under DOE Phase II grants.

Related Research or R&D

The BNL SMD has world-class experience in superconducting magnets of practically all kinds. It pioneered in the metallic insulation techniques that were used for HTS magnets on other PBL/BNL projects^[14]. The PBL/BNL team also built and successfully tested an HTS/LTS^[19] hybrid magnet with advanced quench protection. Of particular interest to Phase II is BNL's experience with the HTS solenoid for superconducting magnet energy storage (SMES)^[18] that developed technology that will be applied to this Phase II—e.g., 12 mm wide HTS tape and metallic insulation. Another HTS project is the 25 T solenoid for IBS, which is now being fabricated at BNL and uses the most advanced HTS that is currently available.

Team Qualifications; Where and How Tasks Will Be Done.

Dr. Stephen Kahn, PBL, will be the project Principle Investigator (PI). Dr. Kahn has 30 years of experience with superconducting accelerator magnets. He has worked as a PI on four previous SBIR grants. He has worked at the Advanced Accelerator Group at BNL on neutrino factory and muon collider R&D. His previous experience at Brookhaven has been broad, including work on high energy physics experiments (neutrino bubble chamber experiments and the D0 experiment) and superconducting accelerator magnets (for ISABELLE, RHIC, the SSC and the APT). Work to design superconducting magnets included 2D and 3D finite-element field calculations using the Opera2d and Tosca electromagnetic design programs along with structural finite-element calculations with ANSYS.

Robert J. Weggel, PBL, has had over 50 years of experience as a magnet engineer and designer at the Francis Bitter National Magnet Laboratory at MIT and Brookhaven National Laboratory and as a consultant in magnet design. He has authored over 100 peer-reviewed articles concerning resistive and superconducting magnets as well as hybrid high-field versions. He has had extensive experience optimizing magnets for various uses including solid-state research, accelerator and medical applications. He has contributed extensively to “*Solenoid Magnet Design*,” by Dr. D.B. Montgomery, and was principal proofreader, editor and equation-corroborator for the 682-page textbook “*Case Studies in Superconducting Magnets*,” by M.I.T. professor Y. Iwasa.

Ronald M. Scanlan, PBL, has had 35 years of experience with superconducting magnets and materials at General Electric R&D Laboratory and Lawrence Livermore (LLNL) and Lawrence Berkeley National Laboratories (LBNL). From 1999 until his retirement from LBNL in 2003, he was the Group Leader for Superconducting Wire and Cable Development. He was responsible for the U. S. Department of Energy, Division of High Energy Physics, Conductor Development Program. From 1995 to 1999 he was Program Head for Superconducting Magnet Development at LBNL, supervising the building and testing of a world-record 13 T Nb₃Sn dipole magnet. Earlier in his career, he was responsible for development of Nb₃Sn conductor for the MFTF fusion magnet (14-T solenoid) at the LLNL. He is the author or co-author of over 100 publications on superconducting magnets and materials. In 1991 he shared the IEEE Particle Accelerator Conference Award with Dr. Larbalestier “for the development of NbTi superconducting material for high current density application in high field superconducting magnets.”

Dr. Erich Willen, PBL, will contribute his expertise in the areas of magnet design and magnetic field quality. He previously served as PI on a related SBIR entitled “Magnet Coil Designs Using YBCO High Temperature Superconductor.” His experience on this previous SBIR will be useful in evaluating the design options being explored in this new SBIR. Dr. Willen has over 30 years of experience with high field magnets and served as the BNL magnet division head, Project Head for the RHIC Helical Magnet System and Project Head for the BNL-built magnets for the US LHC project.

Ramesh Gupta, BNL, will supervise the work performed at the BNL Superconducting Magnet Division, which will focus on the winding and testing of coils, including the manufacturing of the parts needed. Dr. Gupta has more than three decades of experience in the design of superconducting accelerator magnets for various applications. His current interest includes developing and demonstrating high field and HTS magnet designs and technology for particle accelerators and beam lines. He was PI for the Phase II STTR with PBL on “A Hybrid HTS/LTS Superconductor Design for High-Field Accelerator Magnets”. He is also sub-grant PI of several previous Particle Beam Lasers, Inc. SBIRs. Among major other projects, Dr. Gupta is PI for developing and building a 25 T, 100 mm bore solenoid for the Institute for Basic Science (Korea), as a critical part of the Axion search experiment. Dr. Gupta was also PI for the development of HTS magnets for RIA, FRIB and sub-grant PI of an HTS magnet for superconducting magnetic energy storage (SMES). Dr. Gupta has worked on conventional LTS cosine-theta magnet designs (an area that he still continues to pursue) for RHIC and SSC. Dr. Gupta has taught several courses on superconducting magnets at U.S. Particle Accelerator Schools.

Dr. Igor Zaliznyak, BNL, is an expert in applying neutron scattering methods to studying quantum condensed matter, especially quantum magnets and superconductors. Dr. Zaliznyak has extensive experience in using superconducting magnets for his neutron-scattering studies. Throughout his career Dr. Zaliznyak used neutron-scattering magnets at many facilities around the world and thus has first-hand knowledge of the requirements and limitations of superconducting magnets for neutron scattering. Dr. Zaliznyak has made important contributions to neutron-scattering instrumentation. He led a team that developed the conceptual design and obtained the funding for a \$13.2 million hybrid spectrometer that was built and commissioned at the Spallation Neutron Source, a DOE Office of Science user facility at Oak Ridge National Laboratory. That instrument is now capable of uniquely distinguishing magnetic excitations from lattice vibrations, a capability that Zaliznyak is currently applying in his studies of

quantum matter. Dr. Zaliznyak will provide expertise and guidance for developing HTS magnet systems with specifications consistent with the requirements of neutron-scattering experiments.

Piyush Joshi, BNL, is Head of the Electrical Systems group at the BNL Superconducting Magnet Division and will be primarily responsible for the quench protection system.

Michael Anerella, BNL, is Head of the Mechanical Engineering group at the BNL Superconducting Magnet Division and will be primarily responsible for the magnet engineering of the Proof-of-Principle Magnet and for leading the cost estimations of future magnets.

Dr. William Sampson, BNL, is a senior scientist at the BNL Superconducting Magnet Division and recipient of the IEEE Council on Superconductivity Award for Significant and Sustained Contributions in the Field of Applied Superconductivity. Dr. Sampson was responsible for developing and testing the conical coil during Phase I and will play a major role in building and testing the Phase II magnet.

Shresht Joshi, BNL, is a scientific associate at the BNL Superconducting Magnet Division and will play a central role in winding new coils and building hardware and software for magnet testing.

Steve Plate, now BNL, is currently a senior mechanical engineer at the BNL Superconducting Magnet Division and was responsible for magnet engineering, cad models and 3-d ANSYS analysis during Phase I. Mr. Plate is expected to join PBL at the beginning of Phase II after his retirement from BNL.

All work will be done at BNL or at PBL offices, often located in employee's homes. The primary place of work for Dr. Stephen Kahn, a PBL employee and the project Principle Investigator (PI), is BNL where he has a guest appointment and an office and has access to relevant BNL software and facilities. Frequent meetings will be held both over phone conferences and face to face. The tasks will be done in a manner consistent with similar efforts done by our highly qualified team on previous projects.

How the Research Effort Could Lead to a Product.

If Phase II is funded, the research effort will lead to the demonstration of a very high field solenoid to extend greatly the power of neutron-scattering experiments. Additionally, the prototype ~17 T fully HTS test magnet proposed here is a compact solenoid that would outperform existing LTS magnets for lower field applications. Such magnets are currently unavailable, and their development and commercialization are highly desirable. For a more complete description of the excellent commercialization potential that this project has, please consult the commercialization plan associated with this proposal.

Managerial controls for a successful project.

To ensure success, PBL will hold regular technical meetings and compare progress made against the performance schedule. The technical staff will meet to ensure that important milestones are being met in a timely way. In some of these meetings, PBL senior management will participate. The team will identify any problems and find ways to solve them, as it has in several previous Phase I and Phase II SBIRs and STTRs.

PBL has considerable experience with the DOE SBIR program, having completed several SBIR research efforts over the years. As such, PBL personnel are well versed in the reporting and administrative needs that will be an important part of the project proposed herein.

Consultants and Subcontractors

Brookhaven National Laboratory (BNL), 2 Center Street, Upton NY 11973-5000 is the proposed subcontractor. The total subcontract is proposed to be \$450,000 for the two year project. As identified in the attached letter from BNL, the certifying official is Erick Hunt, ehunt@bnl.gov, (631) 344-2103. BNL has partnered with PBL, Inc. in several SBIR/STTR Phase I and three SBIR Phase II projects constructing two YBCO solenoids, one of 100-mm bore and the other of 25-mm bore; the latter tested without

quenching to nearly 16 T, a world record for an all-HTS magnet at that time, and a hybrid HTS/LTS dipole.

References

1. Nat. Res. Council, "High Magnetic Field Science and Its Application in the United States: Current Status and Future Directions," Washington, DC, Nat. Acad. Press. <https://www.nap.edu/read/18355>, ISBN 0309387787, 9780309387781 (2013) doi: <https://doi.org/10.17226/18355>.
2. Workshop on Probing Matter with X-Rays and Neutrons at the National High Magnetic Field Laboratory, Tallahassee, FL, May 10-12, 2005.
3. B. Winn, M.B. Stone, et al., Workshop on Neutron Scattering and High Mag. Fields, Sept. 4-5, 2013, https://neutrons.ornl.gov/sites/default/files/WorkshopReportFINAL_FINAL.pdf. ORNL/TM-2014/652, doi: 10.2172/1410956 (2014).
4. B. Winn, et al. Tech. Report: Ultra-High Field Magnets for X-Ray and Neutron Scattering using High Temperature Superconductors, <https://info.ornl.gov/sites/publications/Files/Pub71968.pdf>. ORNL/TM-2016/712, DOI: 10.2172/1432171 (2017).
5. O. Prokhnenko, et al. Time-of-flight Extreme Environment Diffractometer at the Helmholtz-Zentrum Berlin. Rev. Sci. Instr. **86**, 033102 (2015); doi: 10.1063/1.4913656.
6. HFM/EXED. High Magnetic Field Facility for Neutron Scattering. https://www.helmholtz-berlin.de/pubbin/igama_output?modus=einzel&gid=1939&sprache=en.
7. F.J. Brown, J. Phys.: Conf. Ser. **251**, 012093 (2010).
8. R.B.E. Down, et al., J. Phys.: Conf. Ser. **251** 012092 (2010).
9. O. Kirichek, et al., J. Phys.: Conf. Ser. **400** 052013 (2012).
10. T. Panesor & E. Woodfield, "Neutron scattering," Institute of Physics 2010, https://www.iop.org/publications/iop/2011/file_47455.pdf
11. R. Gupta, et al., "Open-Midplane Dipole Design for LHC IR Upgrade," MT18, Morioka City, Japan (2003).
12. R. Gupta, et al., "Optimization of Open Midplane Dipole Design for LHC IR Upgrade," 2005 Particle Accelerator Conference, Knoxville, TN, USA (2005).
13. R. Weggel, et al., "Open-Midplane Dipoles for a Muon Collider," 2011 Particle Accelerator Conference, New York, NY (2011).
14. Ramesh Gupta, Michael Anerella, Arup Ghosh, Piyush Joshi, Harold Kirk, Seetha Lakshmi Lalitha, Robert Palmer, William Sampson, Peter Wanderer, Holger Witte, Yuko Shiroyanagi, David Cline, Alper Garren, Jim Kolonko, Ronald Scanlan and Robert Weggel, "High field HTS solenoid for a Muon Collider — Demonstrations challenges strategies", IEEE Trans. Appl. Supercond., vol. 24, no. 3, Jun. 2014.
15. R. Gupta, et al., "HTS Quadrupole for FRIB - Design, Construction and Test Results," Presented at the Applied Superconductivity Conference, Charlotte, NC, August 10-15, 2014.
16. R. Gupta, M. Anerella, A. Ghosh, H. Kirk, R. Palmer, S. Plate, W. Sampson, Y. Shiroyanagi, P. Wanderer, B. Brandt, D. Cline, A. Garren, J. Kolonko, R. Scanlan, R. Weggel, "High Field HTS R&D Solenoid for Muon Collider," 2010 Applied Superconductivity Conference, Washington, DC, August 2010.
17. Y. Shiroyanagi, R. Gupta, P. Joshi, H. Kirk, R. Palmer, W. Sampson, P. Wanderer, D. Cline, A. Garren, J. Kolonko R. Scanlan, R. Weggel, "15+ T HTS Solenoid for Muon Accelerator Program," 3rd Int. Particle Acc. Conf. (IPAC 2012).
18. R. Gupta, et al., "Design, Construction and Testing of a Large Aperture High Field HTS SMES Coil," International Conference on Magnet Technology (MT24), Seoul, Korea, October 19, 2015.
19. R. Gupta, M. Anerella, J. Cozzolino, P. Joshi, W. Sampson, P. Wanderer, J. Kolonko, D. Larson, R. Scanlan, R. Weggel and E. Willen, "Design, Construction and Test of HTS/LTS Hybrid Dipole," International Conference on Magnet Technology (MT25), Amsterdam, August 27 - September 1, 2017.
20. R. Gupta, et al., "Status of the 25 T, 100 mm Bore HTS Solenoid for an Axion Dark Matter Search Experiment," 2018 Applied Superconductivity Conference, Seattle, October 28 - November 2, 2018.

Letter of Support from Dr. John M. Tranquada, Neutron Scattering Group Leader at BNL

Condensed Matter Physics & Materials Science Department



Building 734
P.O. Box 5000
Upton, NY 11973-5000
Phone 631 344-7547
Fax 631 344-2739
jtran@bnl.gov

managed by Brookhaven Science Associates
for the U.S. Department of Energy

www.bnl.gov

October 5, 2018

Dr. Ramesh Gupta
Building 902A
Superconducting Magnet Division
Brookhaven National Laboratory
Upton, NY 11973

Dear Ramesh:

I am writing to express my enthusiastic support for the SBIR proposal "HTS Solenoid for Neutron Scattering," from Particle Beam Lasers, Inc., and you.

As Leader of the Neutron Scattering Group at Brookhaven, I am a frequent user of the Spallation Neutron Source (SNS) at Oak Ridge National Lab (ORNL). In the last 10 years, I have published 35 papers involving neutron scattering experiments, with 14 of those involving work at the SNS. I have worked closely with Dr. Barry Winn, who is the lead instrument scientist for the HYbrid SPECTrometer (HYSPEC) and who led a 2016 ORNL study on needs and requirements for ultra-high field magnets for x-ray and neutron scattering.

In my own research, I am particularly interested in the study of copper-oxide superconductors, where interesting charge order can develop that interacts with the superconductivity. An applied magnetic field can be used to depress the superconductivity and enhance the charge order. The fields necessary for this work are > 20 T, which is well beyond current capabilities of magnets made from conventional superconductors. We need a steady-state field, so that we can measure weak diffraction peaks and low-energy antiferromagnetic spin fluctuations.

I am well aware of your considerable experience in designing magnet systems with first and second generation high-temperature-superconductor wires. I am also aware of your productive history with Particle Beam Lasers. We have discussed the issues relevant to practical magnets for neutron scattering experiments at instruments such as HYSPEC, at SNS's first target station, and also at the proposed second target station. You have some innovative ideas on how to deal with several practical challenges with high-field split coil and single-coil magnets.

Again, I strongly support your project. If you are successful, I will be happy to continue to interact on this project and to communicate with instrument scientists at the SNS.

Sincerely yours,

A handwritten signature in blue ink that reads "John M. Tranquada".

John M. Tranquada
Senior Physicist
Neutron Scattering Group Leader